

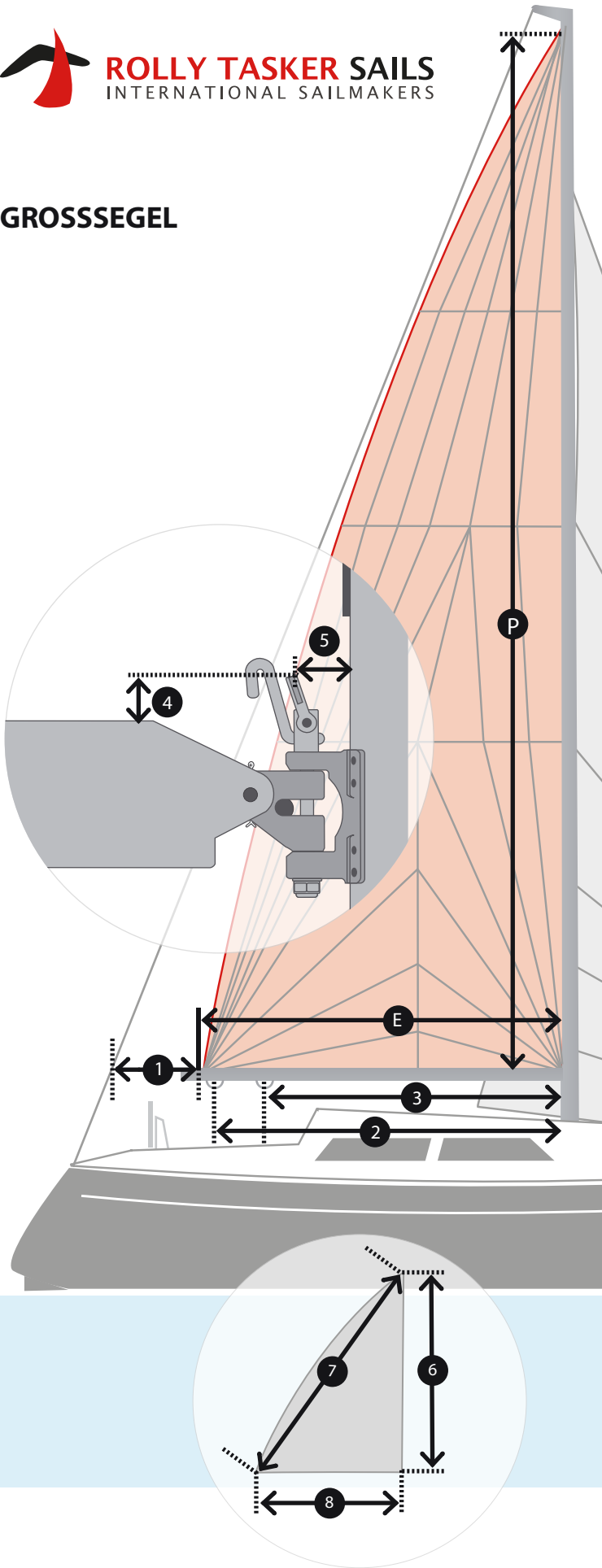

**GROSSEGEL**



Name .....

Schiffstyp .....

**Großsegeltyp**

- Cruise oder  Race oder  Rollgroß  
 Topp-Takelung oder  7/8 Rigg oder  9/10 Rigg

Rollanlage Baum/Mast (Typ) .....

**Riggmaße**

- P** cm Maximale Vorlieklänge (Oberkante Kopfbrett bis Oberkante Baum)  
**E** cm Maximale Unterlieklänge (Hinterkante Mast bis maximale Länge Unterliek)  
**1** cm Horizontale zwischen Schothorn und Achterstag

**Lattung**

- 1+3  Fullbatten  
 2+2  Fat-Head

**Reffmaße**

- 2** cm Hinterkante Mast bis Beschlag erstes Reff am Baum  
**3** cm Hinterkante Mast bis Beschlag zweites Reff am Baum

**Halsbeschlag (Cutback)**

- 4** cm Oberkante Baum bis Halsschäkel  
**5** cm Hinterkante Mast bis Halsschäkel

Reffvariante:  Einleinen-Reffsystem  Bindereff

Cunningham-Kausch:  ja  nein

**Maße altes Segel (gespannte Lieken)**

- 6** cm Vorliek  
**7** cm Achterliek (ohne Rundung)  
**8** cm Unterliek

## GROSSEGEL

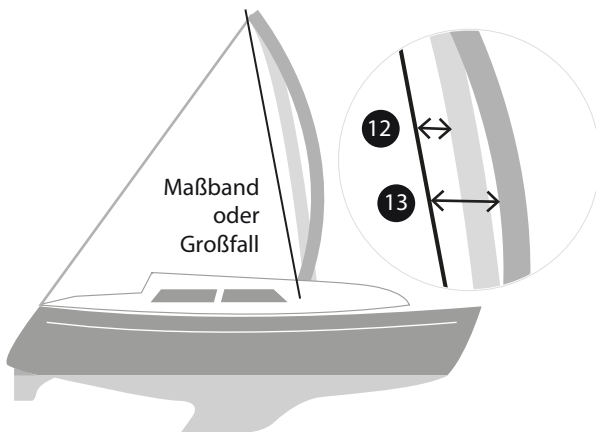
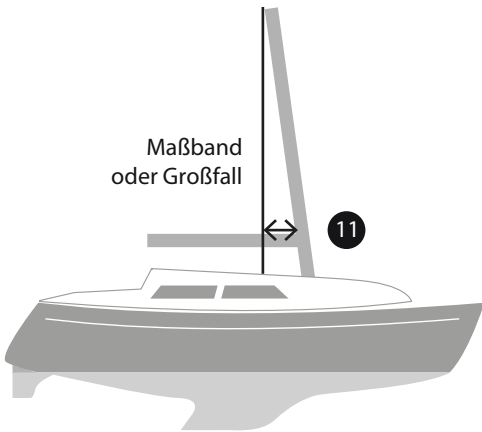
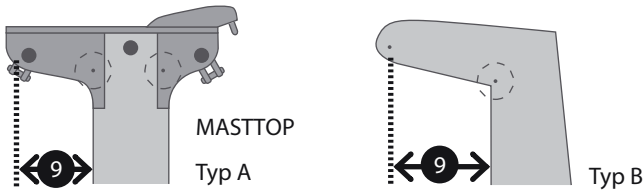

### Mastprofil



### Masttop, Galgenlänge



### Mastrutschertypen

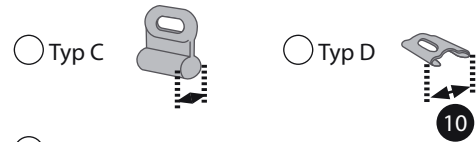
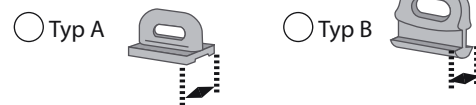

### Mastfall

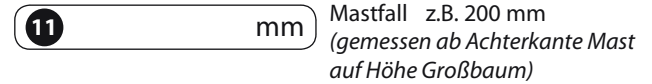

### Achterstag



### Mastkrümmung

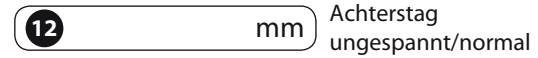

Position max. Mastkrümmung (z.B. 1/2 oder 2/3 von unten)

### Baumprofil

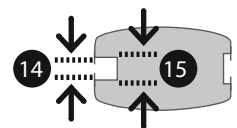
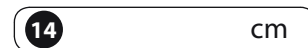

### Unterliek

- fest oder  lose
- Baumrutscher in Nut oder auf Schiene vorhanden
- Klettgurt